



R CAR

Research Council for Automobile Repairs

**The Procedure for Conducting a Low Speed 15 km/h Offset
Insurance Crash Test to Determine the Damageability and
Repairability Features of Motor Vehicles**

**The Procedure for Conducting a Low Speed 15 km/h Offset Insurance Crash
Test to Determine the Damageability and Repairability Features of Motor
Vehicles**

Issue 2.1 :September 2006

INDEX

1.0 INTRODUCTION	1
2.0 SCOPE	1
3.0 DEFINITIONS	1
4.0 TEST INSTALLATION AND PREPARATION OF THE TEST VEHICLE FOR FRONT IMPACT.....	2
5.0 PROPULSION AND COURSE OF THE TEST VEHICLE.	4
6.0 TEST SPEED	4
7.0 MEASUREMENTS AND CHECKS TO BE MADE ON THE TEST VEHICLE	4
8.0 TEST INSTALLATION AND PREPARATION OF THE TEST VEHICLE FOR REAR IMPACT	5
9.0 THE TEST VEHICLE	6
10.0 THE TEST REPORT	6
11.0 OPTIONS	7

Appendices:

Insurance Crash Test Procedure: Front [Left and right-hand-drive].....	<i>Appendix 1</i>
Insurance Crash test procedure: Rear	<i>Appendix 2</i>
Mobile Barrier.....	<i>Appendix 3</i>
Panel Gap Measurement	<i>Appendix 4</i>

1.0 INTRODUCTION

This document details the minimum procedures required for carrying out low speed 15 km/h offset insurance crash tests for the purposes of determining a vehicle's damageability and repairability features.

2.0 SCOPE

This procedure applies to power driven passenger vehicles of up to 2.5 tonnes mass. Other vehicles may be similarly treated if required by the manufacturer or the test house.

3.0 DEFINITIONS

3.1 Vehicle Restraint System

Interior fittings and devices intended to restrain the occupants.

3.2 Airbag (Supplementary Restraint System)

A device installed to supplement safety belts and restraint systems in motor vehicles, i.e. systems which, in the event of a severe impact affecting the vehicle, automatically deploy a flexible structure intended to limit, by compression of the gas within it, the gravity of the contact of one or more parts of the body of the occupant of the vehicle within the interior of the passenger compartment.

3.3 Vehicle Width

The distance between two planes parallel to the longitudinal median plane and touching the vehicle on either side of the said plane at the vertical central line of the vehicle. Rear view mirrors, side marker lamps, tyre pressure indicators, direction indicators, position lamps and the deflected part of the tyre side walls immediately above the point of contact with the ground should be excluded. (This is usually but not always the Wheel arch)

3.4 Adjustable Barrier/Former

A non-deformable device conforming to the dimensions shown in Appendix 1 .

3.5 Overlap/Offset

The percentage of the vehicle's front or rear width, as defined in 3.3, directly in line with the edge of the adjustable barrier former or mobile barrier.

3.6 Mobile Barrier

A device conforming with the fixed dimensions shown on the drawing in Appendix 3. (The remaining dimensions are advisory only).

3.7 Unladen Kerb Mass

The mass of the vehicle in running order unoccupied and unladen, but complete with full fuel complement (as described by the vehicle manufacturer), coolant, lubricant, tools and spare wheel (if these are supplied as standard by the vehicle manufacturer).

4.0 TEST INSTALLATION AND PREPARATION OF THE TEST VEHICLE FOR FRONT IMPACT

4.1 Testing Ground

The test area shall be large enough to accommodate the acceleration track, barrier and technical installations necessary for the test. The last part of the track, for at least 5 metres before the barrier, shall be horizontal, flat and smooth.

4.2 Adjustable Barrier/Former

The barrier shall consist of an adjustable former, whose dimensions conform to those shown in Appendix 1. The front face of the former shall be perpendicular to within $\pm 1^\circ$ of the direction of travel of the test vehicle. The former may be secured to a fixed barrier, the front face of which is vertical to within $\pm 1^\circ$, or may be anchored directly to the ground, or placed on the ground with, if necessary, additional arresting devices to restrict its movement. The mass of the barrier/former shall exceed twice that of the vehicles under test.

4.3 Orientation of the Adjustable Barrier/ Former

The orientation of the adjustable former shall be such that contact of the vehicle with the former shall be on the steering column side.

4.4 Alignment of Test Vehicle to Former

The test vehicle shall overlap the face of the former by 40% ± 25 mm. [Appendix 1].

4.5 The Test Vehicle

The test vehicle shall be previously undamaged and representative of the series production (usually the most popular model) and include all the equipment normally fitted for that model. Some components may be replaced by equivalent masses where the substitution clearly has no noticeable effect on the results.

4.6 The Test Vehicle Mass

4.6.1 For the test, the mass of the vehicle submitted shall be at least the unladen kerb mass, increased by 75 kg to account for a dummy, as in 4.9.1. If this mass cannot be achieved, the vehicle may be tested at the lower mass presented, with the agreement of the manufacturer and the test house, and a note to this effect should be included in the test report.

4.6.2 The test vehicle shall be ballasted to represent a full load of fuel as specified by the manufacturer with a $\pm 5\%$ tolerance. Alternatively a fuel substitute may be introduced into the fuel tank of the test vehicle.

4.6.3 All other fluid systems may be empty; however, the liquid mass should be supplemented with ballast to achieve the test mass where appropriate. Air conditioning systems containing environmentally unsuitable refrigerant should be drained to protect the environment, and pressure checked after impact to detect any potential leakage.

4.6.4 The mass of any on board test apparatus shall be offset by removing ballast or components which have no effect on the test results.

4.6.5 The mass of any ballast or on board test apparatus or the removed components shall not change each axle reference load by more than 5%, each variation not exceeding 20 kg.

4.6.6 By agreement with the manufacturer and the test house, the vehicle may be tested at a higher mass than determined by the provisions of 4.6, and a note to this effect should be included in the test report.

4.6.7 The final total test mass of the vehicle resulting from the provisions of Section 4.6 shall be recorded in the test report.

4.7 Test Vehicle Passenger Compartment Adjustments

4.7.1 Position of Steering Wheel

The steering wheel, if adjustable, shall be placed in the midway position between the limits of its range.

4.7.2 Glazing

The moveable glazing may be open or closed, in accordance with manufacturer or test house requirements.

4.7.3 Gear Change Lever

The gear lever shall be in the neutral position.

4.7.4 Handbrake

The handbrake shall be in the “off” position. (With some test installations, a certain amount of handbrake application to create drag is acceptable, provided there is a provision to account for the deceleration which takes place when the test vehicle is no longer under the influence of the propelling device, and that the calculation for such deceleration is clearly noted in the test report).

4.7.5 Pedals

The pedals shall be in their normal position. However, if adjustable, they should be in the mid position.

4.7.6 Doors

The doors shall be closed, but not locked. However, where special devices are present that unlock doors in the event of impact, the doors may be locked in order to test these devices if required.

4.7.7 Opening Roof (Sun Roof)

The sun roof shall be in the closed position.

4.7.8 Soft Top (Convertible)

The soft top shall be in the “up” position.

4.7.9 Head Restraints

Adjustable head restraints shall be in the uppermost position.

4.7.10 Seat Belt Upper Anchor Points

Adjustable seat belt upper anchor points shall be in the mid position.

4.7.11 Seats

4.7.11.1 Position of Front Seats

Seats adjustable longitudinally shall be placed in the mid position or the nearest locked position to the mid point. Seats adjustable for height shall also be placed in the mid point.

4.7.11.2 Position of Front Seat Backs

Seat backs that are adjustable shall be placed such that the dummy is as close as possible to that recommended by the manufacturer for “normal” use. In the absence of any recommendation, the seat back shall be 25° towards the rear from vertical.

4.8 Ignition Switch

To determine whether or not the SRS system deploys, the ignition switch shall be placed in the “on” position utilising the vehicle’s normal ignition key. For the duration of the test the key may be temporarily secured in the “on” position with tape or other self-adhesive material. The engine should not be running except where it is used to propel the test vehicle.

4.8.1 Where the vehicle is fitted with an airbag(s) system, the diagnostic indicator light in the instrument panel shall be observed long enough to establish that the system is in working order when the ignition is switched “on”. (Normally the diagnostic indicator light extinguishes after a few seconds to indicate that the system is functional. This will also test electronic seat belt pre-tensioner systems where they are fitted).

4.9 Dummies

4.9.1 A simple ballast dummy corresponding to a 75kg male, or an anthropomorphic test device (ATD) corresponding to a 50th percentile male, may be installed at the driver’s position. Alternatively the vehicle may be ballasted by other means at the driving position. The dummy/ballast mass shall be recorded in the test report.

4.9.2 The vehicle’s own restraint systems shall be utilized for dummy/ballast restraint.

5.0 Propulsion and course of the test vehicle

5.1 The test vehicle may be propelled by its own engine or by any other propelling device.

5.2 At the moment of impact the test vehicle shall not be subject to the influence of any additional steering or propelling device.

5.3 The course of the test vehicle shall be such that it satisfies the requirements of 4.3 and 4.4.

6.0 TEST SPEED

The test vehicle speed within 1 metre of impact with the barrier shall be 15+1-0 km/h. The actual impact speed shall be recorded in the test report.

7.0 MEASUREMENTS AND CHECKS TO BE MADE ON THE TEST VEHICLE

7.1 External panel gap measurements may be taken before and after each impact in accordance with the suggested recording form at Appendix 4. Alternatively, other significant measurements may be taken with the agreement of the test house and the manufacturer.

7.2 Accelerometers may be placed around the vehicle for data gathering purposes. The base of the “B” post on both sides of the test vehicle may be utilised as a vehicle reference point in the X direction. Accelerometers may also be placed on the airbag ECU or any other position in accordance with the requirements of the test house or manufacturer.

7.2.1 Accelerometers shall be rigidly mounted in the structure using a material which does not interfere with signal transmission and does not impart any of its properties into the signal. Filtration shall be to Class 60 of SAE J211 requirements.

7.3 Colour photographs shall be used to record images of the test vehicle before and after each impact.

7.4 The test vehicle shall have such underbody dimensions checked and recorded as are deemed necessary. Measurements shall be carried out before and after each impact to determine any distortion. Any suitable measuring equipment may be used, provided the same reference points are used each time and the equipment produces a permanent record of the data.

7.5 The test vehicle shall have its four wheel geometry checked before and after impact. Any suitable measuring equipment may be used, provided it records all relevant geometry figures and the equipment produces a permanent record of the data.

7.6 Where the test vehicle is fitted with seat belt pretensioners, which operate when the vehicle is subject to a frontal impact, the pretensioners shall be checked before impact to see that they are capable of operation and after impact to determine whether the mechanism has deployed. The condition after impact shall be noted in the test report.

7.7 Where the test vehicle is fitted with an airbag system, the condition of the airbag(s) after impact shall be noted in the test report.

8.0 TEST INSTALLATION AND PREPARATION OF THE TEST VEHICLE FOR REAR IMPACT

The test installation and preparation of the vehicle shall be similar to that for the front impact, but with the following additions:

8.1 The Mobile Barrier

8.1.1 The mobile barrier shall conform to the dimensions shown as “fixed” on the drawing in Appendix 3. (The remaining dimensions are advisory only). The axles shall be accurately aligned and secured to ensure a straight course.

8.1.2 The mobile barrier shall be equipped and/or restrained in such a way that after the initial contact with the test vehicle no additional unintentional impact takes place to the test vehicle.

8.1.3 The mobile barrier shall be propelled in accordance with 5.1 and shall comply with 5.2.

8.1.4 The mobile barrier shall have a mass of 1400 kg \pm 5 kg.

8.2 The Test Speed

8.2.1 The mobile barrier test speed within 1 metre of the subject vehicle shall be 15+1-0 km/h. The actual test speed shall be recorded in the test report.

9.0 THE TEST VEHICLE

9.1 The test vehicle shall comply with 4.5, but may have already been the subject of a frontal impact. It is for the vehicle manufacturer or the test house to determine that the test vehicle is able to withstand a further impact. This can usually be determined by ensuring that the damage sustained during the first impact will have no effect on any results of the second impact.

9.2 The test vehicle shall be placed in the test area in such a way that the rear of the test vehicle presents itself for impact on the appropriate side by the mobile barrier, as determined by the manufacturer or test house. (Normally this will be opposite the steering column side, unless there is evidence to show that the opposite side is more appropriate). The position shall ensure that the mobile barrier overlaps the rear of the test vehicle by 40% \pm 25 mm. and at an angle of 10 degrees to the front face of the mobile barrier [Appendix2].

9.3 The test vehicle shall be stationary with its parking brake in the “off” position. However, mechanisms may be required to control the forward movement of the test vehicle due to its gain of momentum at the time of impact.

10.0 THE TEST REPORT

It is suggested that the test report contain the following information:

10.1 Manufacturers name

10.2 Vehicle model

10.3 Vehicle derivative (incl trim level)

10.4 Vehicle identification number (vin)

10.5 Test house identification number (if any)

10.6 Test house name and address

10.7 Date and time of impacts

10.8 Actual impact speeds

10.9 Total mass of test vehicle. (Includes kerb mass, ballast mass, dummy mass, and on board equipment)

10.10 Mass of test dummy.

10.11 Mass of ballast.

10.12 Mass of on board equipment.

10.13 Front to rear mass split

10.14 Total vehicle width (as para 3.3)

10.15 Adjustable barrier offset from the centre in mm (for front impact). [Appendix 1].

10.16 Test vehicle offset from the centre in mm (for rear impact). [Appendix 2].

10.17 Test vehicle tyre pressures.

10.18 Test vehicle kerb weight.

10.19 Test vehicle damage report(s), (front and rear), including the condition of the airbag(s) and seat belt pretensioners, if fitted.

10.20 Photographs of damage (front and rear).

10.21 Four wheel alignment check (before impact).

10.22 Four wheel alignment check (after impact).

10.23 Test vehicle underbody measurements, as determined by a normal commercially available alignment bench or measuring system (before impact).

10.24 Test vehicle underbody measurements, as determined by a normal commercially available alignment bench or measuring system (after impact).

10.25 A definitive list of the replacement parts, priced from the latest retail list with no discount, required to reinstate the vehicle to its pre-accident condition for both the front and rear impact.

10.26 A record of the number of hours (and the hourly charge) required to remove the damaged parts and replace with new parts, and to repair those items capable of repair, such that the vehicle is reinstated to its pre-accident

condition for both front and rear impacts.

10.27 Signature of senior engineer responsible for crash tests.

Optional

10.28 Transducer location charts (front and rear).

10.29 High speed film specification chart for each camera.

11.0 OPTIONS

11.1 The front and rear test may be recorded digitally, on video tape and/or 16 mm film. Where high speed film is used, the cameras should be set to the vehicle manufacturer's or test house requirements (usually 500 - 1000 FPS).

11.2 The test vehicle may be painted on the outside and underneath using non-reflective material to provide high quality high speed film footage. Underbody components may be painted in differing colours to distinguish them from each other.

11.3 The test vehicle may be marked up as required to provide reference points for high speed film analysis. The target markers shall be placed at 200 mm intervals along the length of the vehicle and on other important areas, in accordance with the vehicle manufacturer's or test house requirements. Door openings may be marked in such a way that any movement during the impact can be detected post impact.

11.4 The whole test procedure may be conducted utilising a pendulum. However, this device shall be capable of producing precisely the results that would have been achieved using a conventional crash test facility, and preparation of the test vehicle for both front and rear impacts shall be in accordance with this procedure.

11.4.1 The test report shall record the pendulum mass and the calculation to determine the pendulum height required to reach the equivalent to 15+1-0 km/h impact speed.

11.4.2 Provision shall be made to restrain the test vehicle after both front and rear impacts, utilising the pendulum.

11.5 Fully instrumented 50th percentile anthropomorphic dummies may be used for the purposes of determining injury data at low speed.

11.6 The rear impact test may be carried out by propelling the test vehicle rearwards into a barrier fitted with a specific attachment that is dimensionally compliant with the fixed dimensions of the mobile barrier. The speed of the impact will vary with the mass of the test vehicle and is determined by:

$$V = 15 \times \sqrt{\frac{1000}{M + 1000}} + 1 - 0 \text{ km/h}$$

Where:

V = Test Speed in km/h

M = Mass of Test Vehicle

Insurance Crash Test Procedure Front.

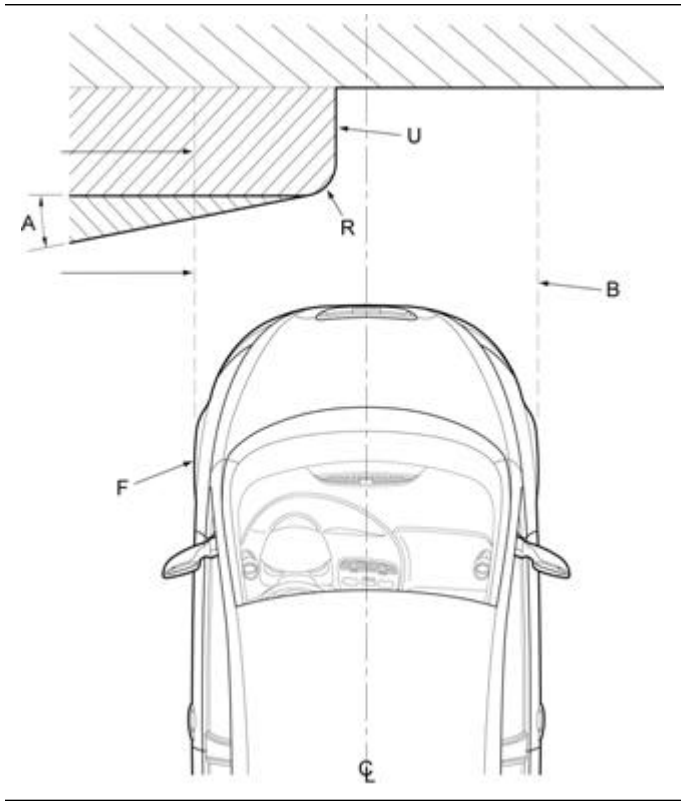

The height of the barrier shall exceed the height of the front of the test vehicle. The test vehicle shall be free of any propelling device at the point of impact.
 Test vehicle mass: kerb weight + 75kg for driver and full fuel tank (or equivalent ballast)

Key:
 U= 40% offset.
 B= Overall vehicle width.
 R= 150mm Radius
 F= Test vehicle
 A= 10 Degree Angle

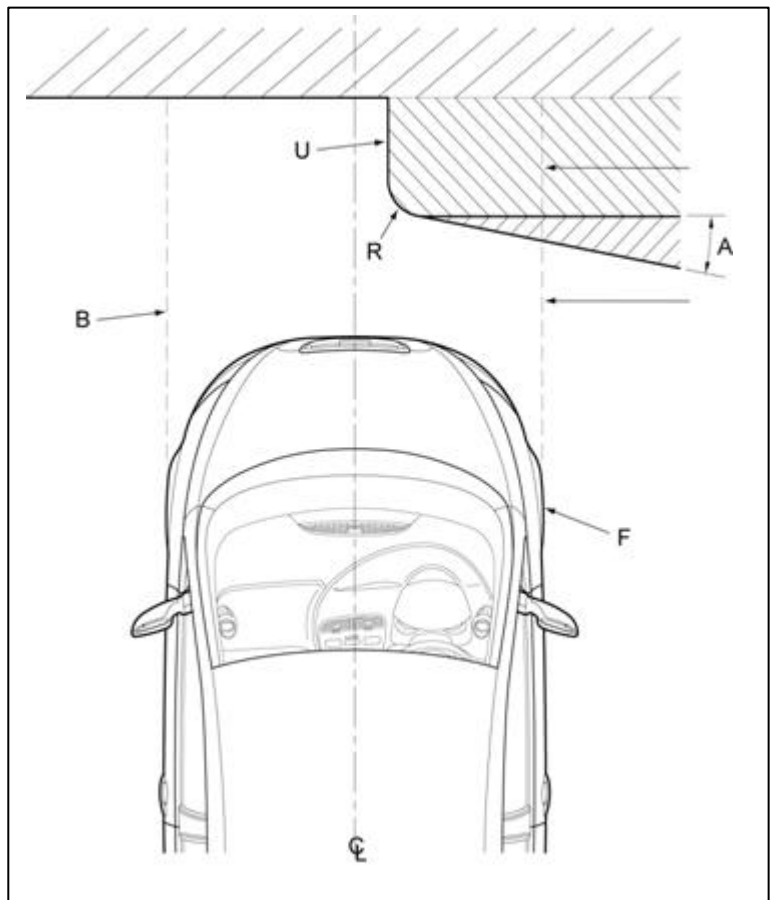

Insurance Crash Test Procedure Rear.

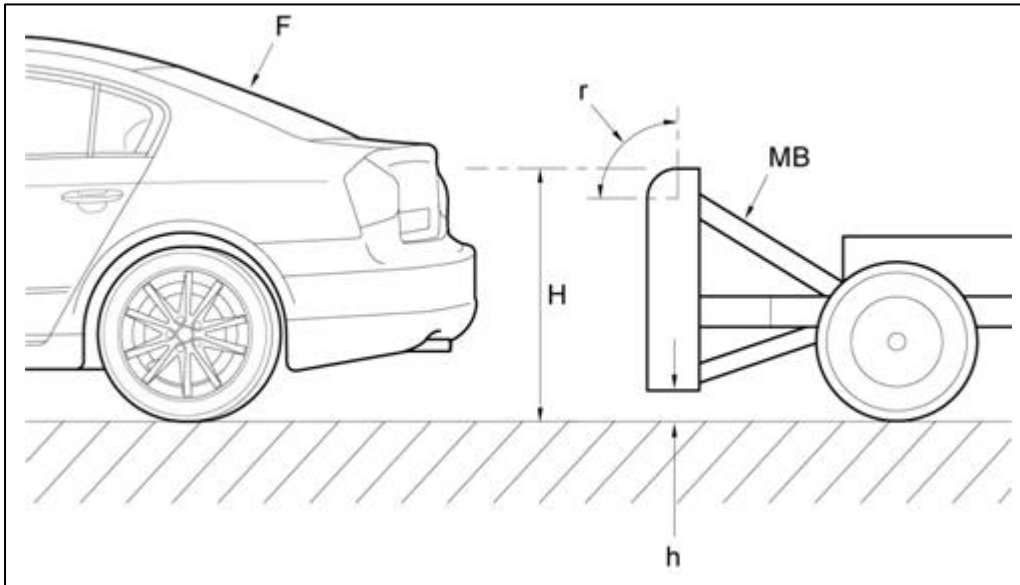

Key:
 MB= Mobile Barrier
 H= Barrier height
 (700mm+/- 10mm)
 h= Ground clearance
 (200mm+/- 10mm)
 F= Test vehicle
 R= Constant radius (150mm)
 r= Constant radius (50mm)
 U= 40% Offset
 B= Overall vehicle width

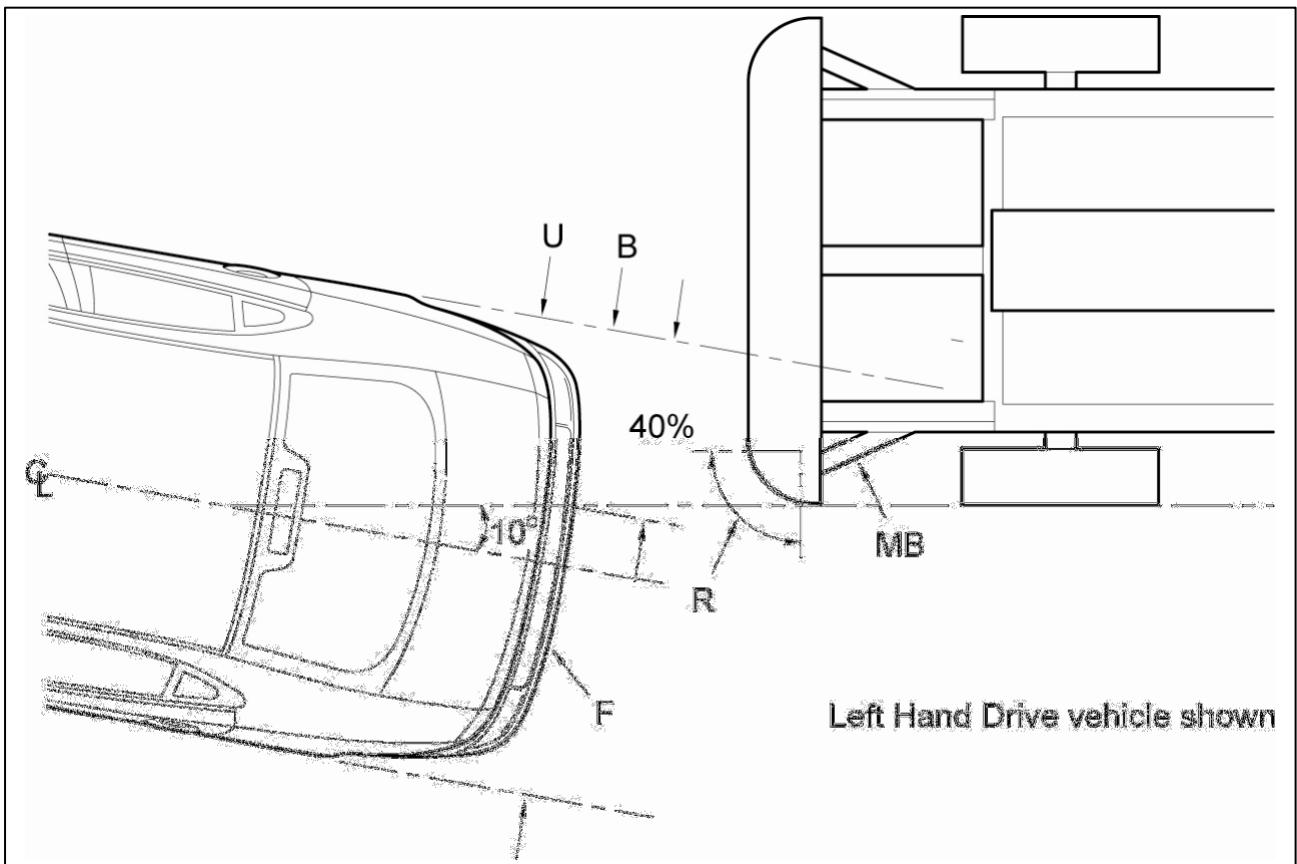

Mobile Barrier dimensions.

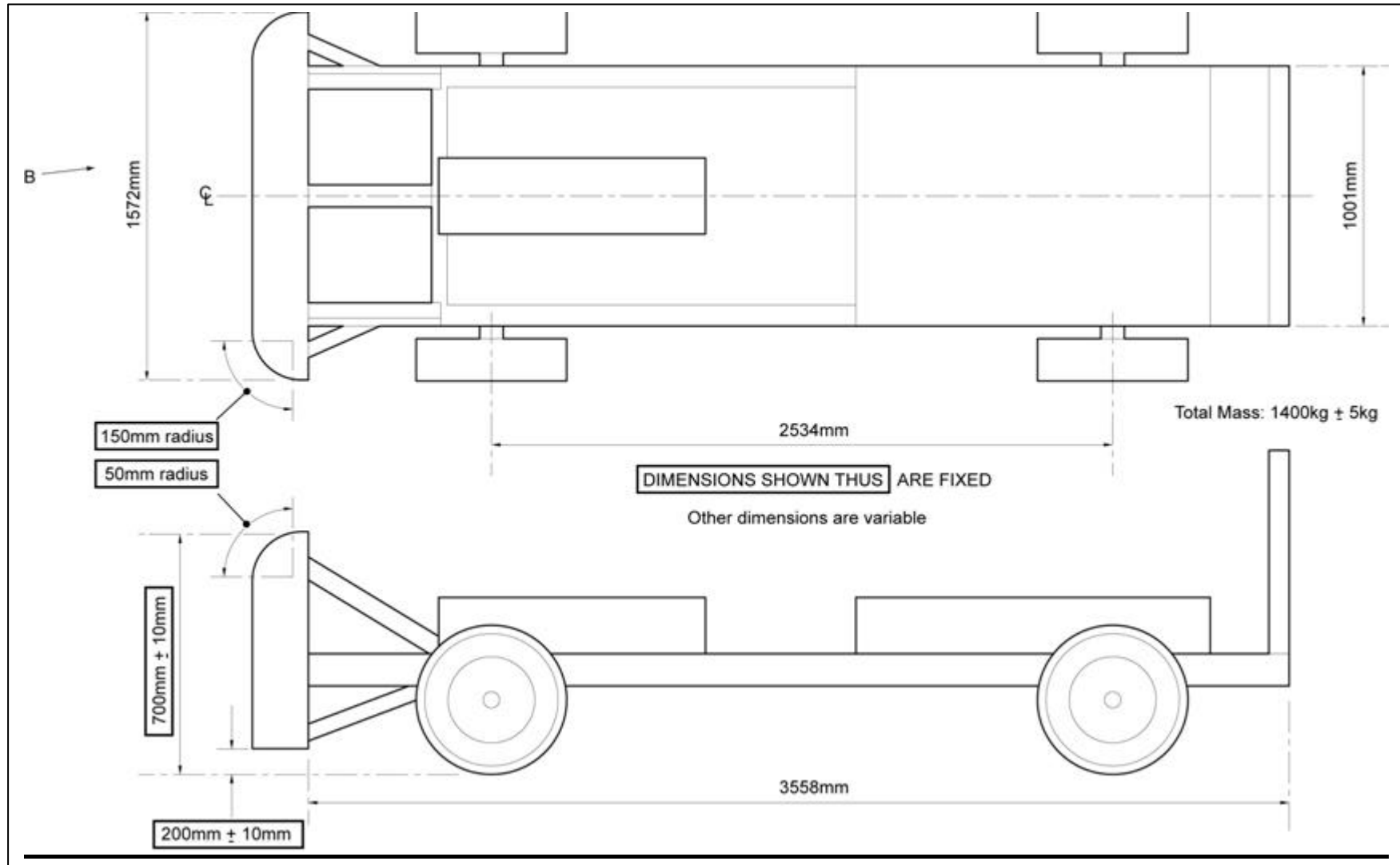

Panel Gap Measurements.

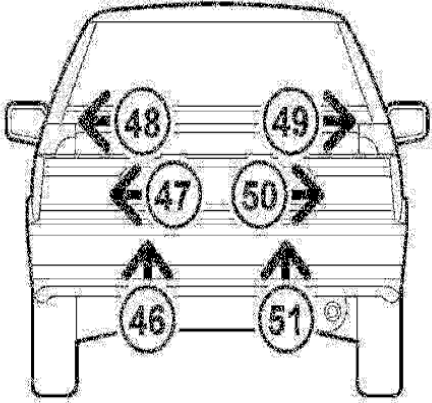
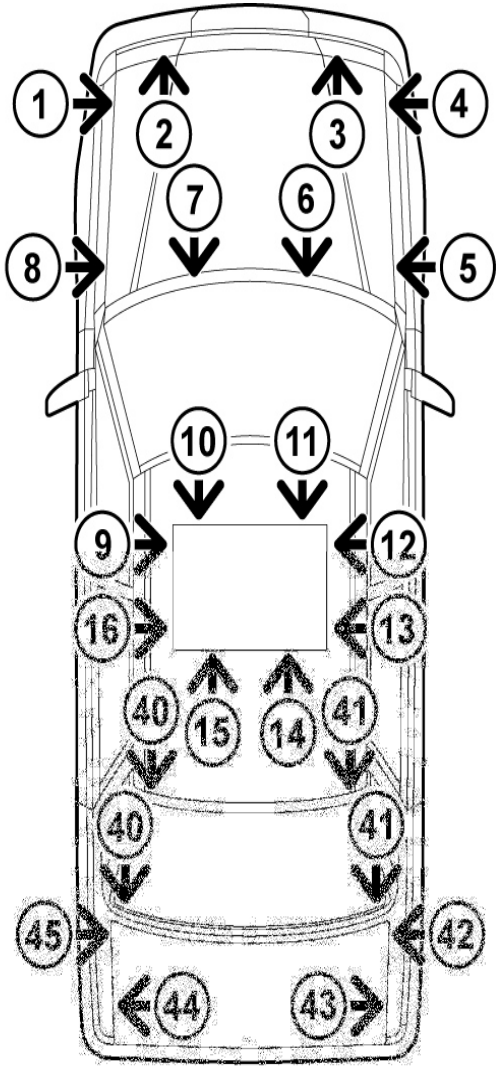
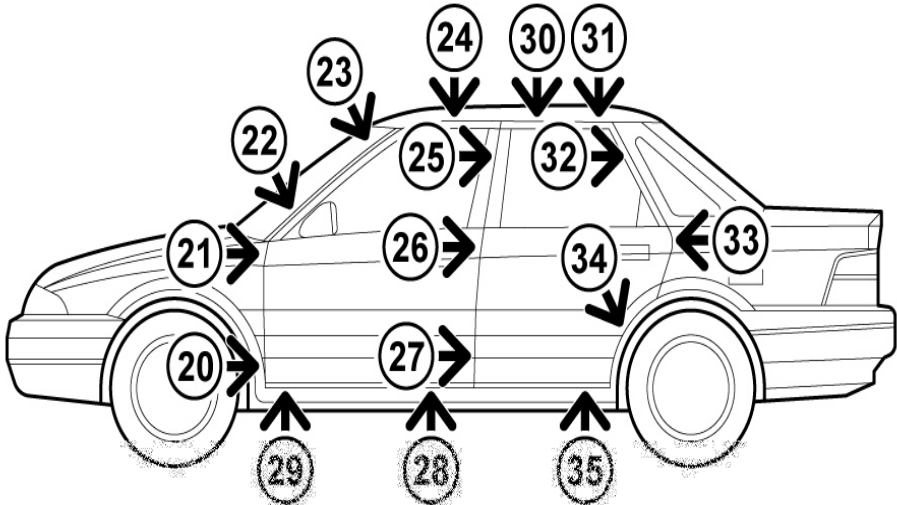

Measuring Points:
 Front Impact: 1-8, 20-29 L+R
 Rear Impact: 40-51
 +2 door 25-27 L+R
 +4 door 30-35 L+R
 Sunroof: 9-16